

UniTorq

UTQ Series

Quarter-Turn Electric Actuators



Innovative Actuators and Controls

www.untorq.com

UniTorq **UTQ Series**

Quarter-Turn Electric Actuators

The rugged **UTQ Actuator** is the result of the accumulation of experience and expertise acquired from over 20 years of valve actuation. With a unique combination of a compact, efficient design utilizing proven electric actuator mechanics and the latest technological enhancements, the **UTQ** is ideally suited for a wide variety of industrial and commercial applications.

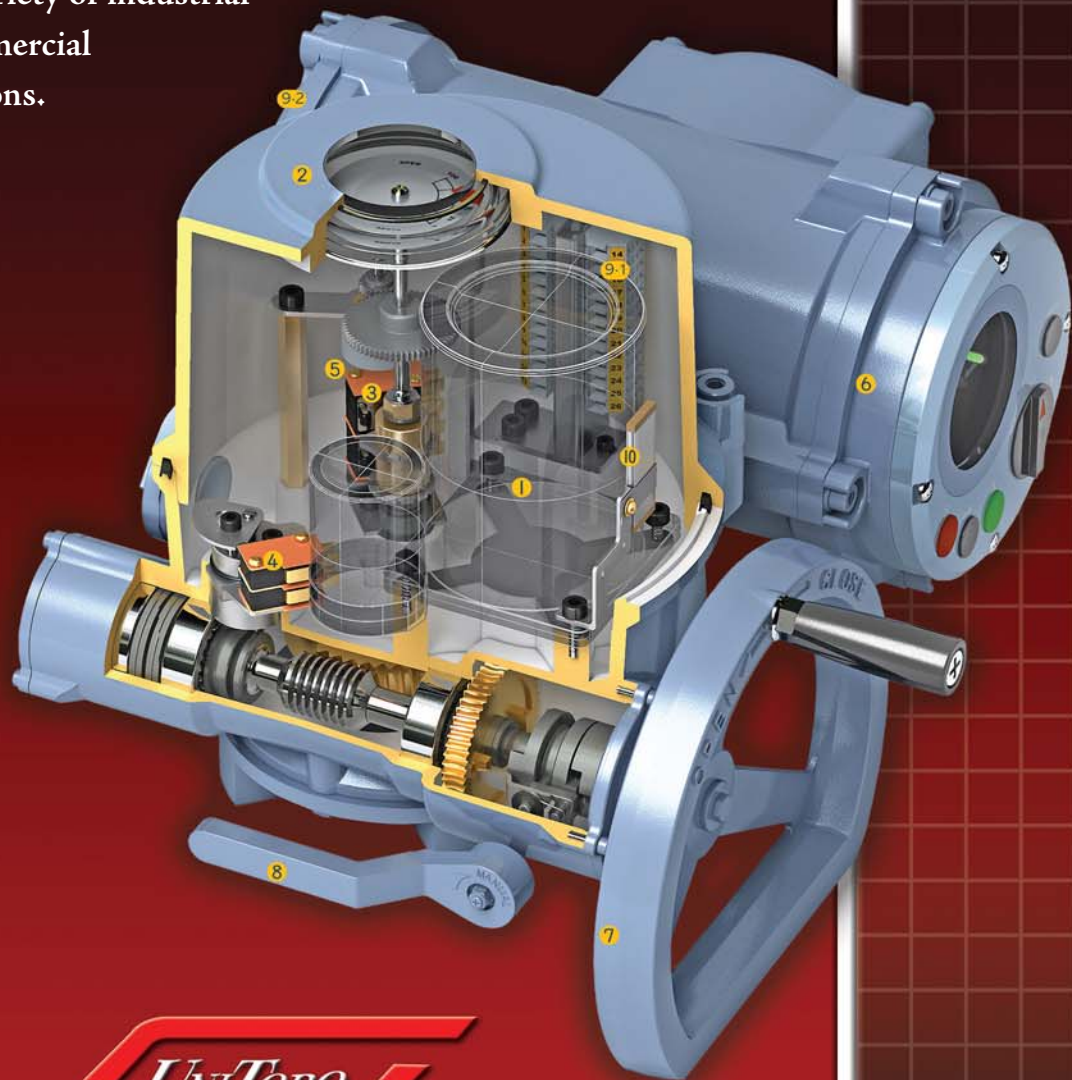

www.unitorq.com

UniTorq **UTQ Series**

Quarter-Turn Electric Actuators

Features & Construction

Sizes: UTQ-1.5 / UTQ-3.0 / UTQ-6.0

- ♦ Motor — split-phase, capacitor driven; 15 minute duty; 115/230v
- ♦ Gearing — hardened steel, machine cut spur gears
- ♦ Enclosure — Nema 4/4X
- ♦ Manual Operation — wrench operated drive shaft, or optional handwheel
- ♦ Limit Switches — 1 each, SPDT at each end of travel
- ♦ Common Options:
 - ♦ Positioning controls (4-20mA)
 - ♦ Anti-condensation or low temperature heaters
 - ♦ 2 additional limit switches
 - ♦ Other options available — consult your UniTorq sales representative

Sizes: UTQ-10 thru UTQ-120

- ♦ Motor — squirrel cage induction motor with embedded thermostat
- ♦ Main Power — Single phase 110/220V; Three phase 220/440/460/480V
- ♦ Housing — durable, compact and corrosion-resistant Aluminum alloy.
- ♦ Enclosure — standard rating to IP68 (submergence to 25 feet for 72 hours)
- ♦ Position Indication — continuous (0-100%) dial-type indicator;
Optional LCD display with integral control unit
- ♦ Limit Switches — 2 each, N.O./N.C., easily screwdriver adjustable
- ♦ Torque Switches — for Open and Close directions
- ♦ Manual Operation — side-mounted handwheel with automatic declutch lever for ease of operation
- ♦ Anti-condensation space heater — thermistor type
- ♦ Common Options:
 - ♦ Integral control unit with non-intrusive push buttons, LED lamps, mechanically and electrically interlocked reversing contactor, phase discriminator, monitor relay and double-sealed terminal block
 - ♦ Automatic phase correction also available
 - ♦ Explosion Proof Enclosure to Class1 / Div. 1 or 2 / Group C or D (Exd IIBT4)
 - ♦ Actuators meet AWWA requirements for Electric Motor Operators
 - ♦ Other options available — consult your UniTorq sales representative





Operational and Dimensional Data

Models UTQ-1.5 to UTQ-6.0 Data Chart

UTQ-Series	Max. Output Torque	Operating Time (90°) 60/50Hz	Output Drive	VA Rating		Rated Current (A)		Weight
				115V	230V	1 Phase		
	in./lbs.	sec.	115V	230V	110V	220V	lbs.	
1.5	150	4 (60Hz)	.55" sq./14mm	70 VA	115 VA	0.37	0.87	6
3	300	8 (60Hz)	.55" sq./14mm	70 VA	115 VA	0.37	0.87	6
6	600	13 (60Hz)	.55" sq./14mm	70 VA	115 VA	0.37	0.87	6

Models UTQ-10 to UTQ-120 Operating Data Chart

UTQ-Series	Max. Output Torque	Operating Time (90°) 60/50Hz	Max. Bore Diameter	Motor		Rated Current (A)				Hand Wheel turns	Weight
				Power	Frame	1 Phase		3 Phase			
	in./lbs.	sec.	inches	W	F	110V	220V	380V	440V	rev	lbs.
10	880	17/21	0.708	15	70	1.12	0.53	n/a	n/a	10	14
20	1760	17/21	1.181	40	80	1.86	0.94	0.30	0.29	10	42
40	3520	26/31	1.575	40	90	1.92	0.99	0.31	0.30	12.5	55
60	5280	26/31	1.575	90	90	3.78	1.46	0.48	0.44	12.5	55
80	7040	34/41	1.850	90	90	3.78	1.46	0.48	0.44	14.5	77
120	10,560	34/41	1.850	180	90	5.12	2.67	0.89	0.83	14.5	77

Dimensional Information:

Models UTQ-1.5 to UTQ-6.0

UTQ-Series	Mounting Flange	Tap / Depth
	ISO / Ø	
1.5	F05/F07	M6/M8
	Ø1.969/Ø2.756	10
3	F05/F07	M6/M8
	Ø1.969/Ø2.756	10
6	F05/F07	M6/M8
	Ø1.969/Ø2.756	10

UniTorq **UTQ Series**

Quarter-Turn Electric Actuators

Dimensional Information:

Models UTQ-10 to UTQ-120

UTQ-Series	Mounting Flange	Tap	A	B	C	D	E	F	G
	ISO / SAE	Depth	mm/in.	mm/in.	mm/in.	mm/in.	mm/in.	mm/in.	mm/in.
010	F05/F07	M6	217 mm	117 mm	n/a	n/a	236 mm	n/a	n/a
	Ø1.969/Ø2.756	10	8.54"	4.61"	n/a	n/a	9.29"	n/a	n/a
020	F07/F10	M8/M10	265 mm	130 mm	296 mm	426 mm	258 mm	137 mm	395 mm
	Ø2.756/Ø4.016	12/15	10.43"	5.12"	11.65"	16.77"	10.16"	5.39"	15.55"
040	F10/F12	M10/M12	287 mm	175 mm	288 mm	463 mm	272 mm	136 mm	408 mm
	Ø4.016/Ø4.921	15/18	11.30"	6.89"	11.34"	18.22"	10.71"	5.35"	16.06"
060	F10/F12	M10/M12	287 mm	175 mm	288 mm	463 mm	272 mm	136 mm	408 mm
	Ø4.016/Ø4.921	15/18	11.30"	6.89"	11.34"	18.22"	10.71"	5.35"	16.06"
080	F12/F14	M12/M16	321 mm	200 mm	293 mm	493 mm	319 mm	155 mm	474 mm
	Ø4.921/Ø5.512	18/24	12.64"	7.87"	11.54"	19.41"	12.56"	6.1"	18.66"
120	F12/F14	M12/M16	321 mm	200 mm	293 mm	493 mm	319 mm	155 mm	474 mm
	Ø4.921/Ø5.512	18/24	12.64"	7.87"	11.54"	19.41"	12.56"	6.1"	18.66"

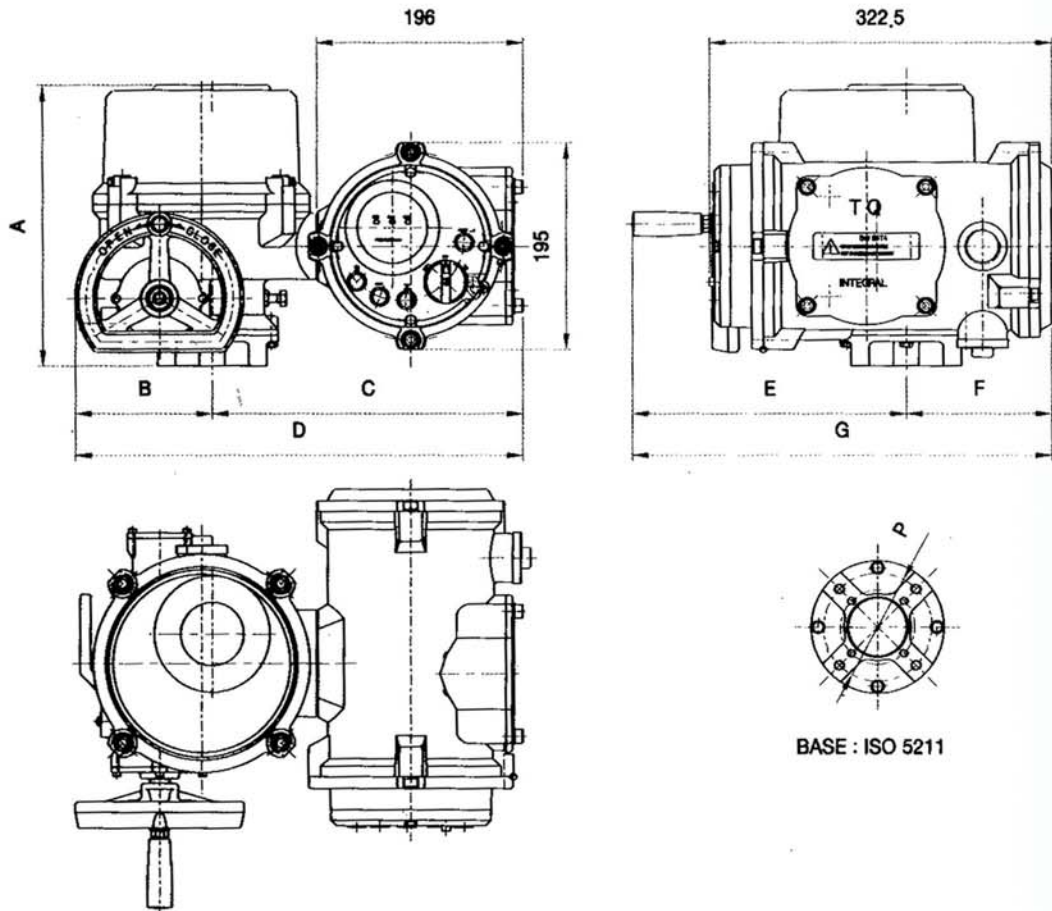

About UniTorq

UniTorq's basic principle is our complete dedication to our customers needs through the manufacturing and distribution of superior actuation products to insure our continued commitment to dependable service and support.

These activities are carried out in a process that is continually improving to implement the latest technological advances and to satisfy the changing needs of our customers.



To Order:

Contact a UniTorq
sales representative at
770.446.7074



UniTorq
2150 Boggs Road • Suite 410
Duluth, GA 30096
www.unitorq.com



UNITORQ

Innovative Actuators and Controls